

Orientalmotor

Electric Gripper
EH Series

*α*STEP AZ Series Equipped

NEW

3-Finger Type

2-Finger Type

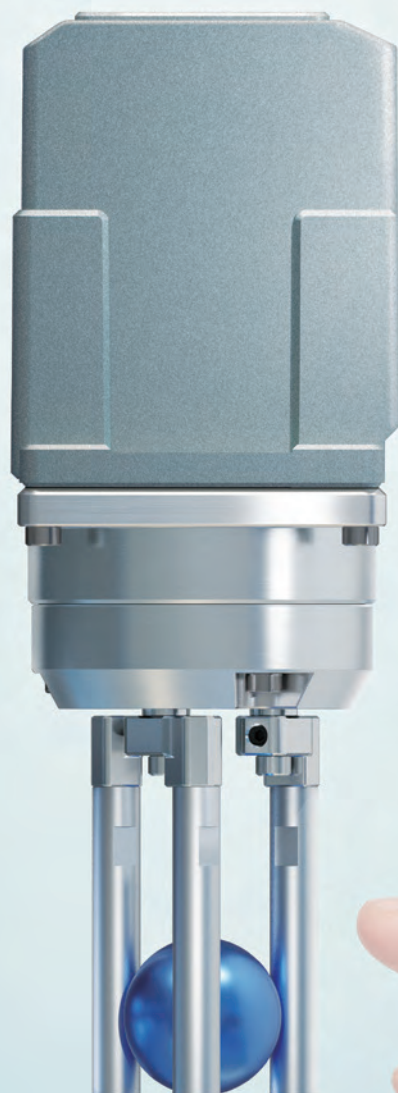

Delicate grip.



Delicate, human-like grip.



Electric Gripper EH Series

αSTEP AZ Series Equipped

An *αSTEP AZ* Series motor equipped with a battery-free absolute sensor combined with an **EH** Series electric gripper. Its delicate grip, like that of a human hand, assists in automation and labor-saving.

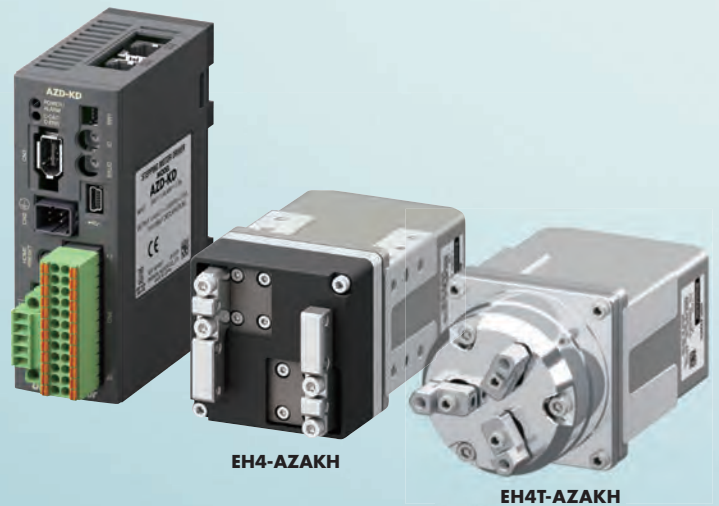

Compact and Lightweight Gripper

- Size: 80.5 mm×36 mm×42.5 mm
- Mass: 200 g
- The **EH3-AZAKH** is shown

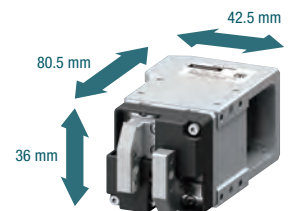

Differentiating “Light and Gentle” from “Firm and Secure”

Minimum grip force 2 N*¹. Maximum grip force 25 N*².

Current control allows the grip force to be minutely changed and regulated. Appropriately grips loads either gently or firmly, whether delicate or slippery.

*1 **EH3-AZAKH** (reference value)

*2 **EH4-AZAKH**

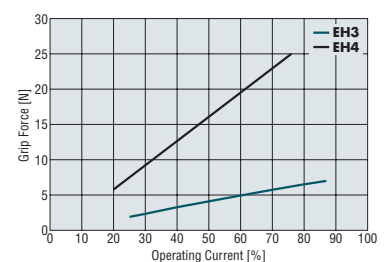

The AZ Series Provides a Delicate Grip

A delicate grip is achieved by fine-tuning the grip force in 1% operating current increments and implementing a slow approach to the load.

●Please prepare attachments (hooks) separately.

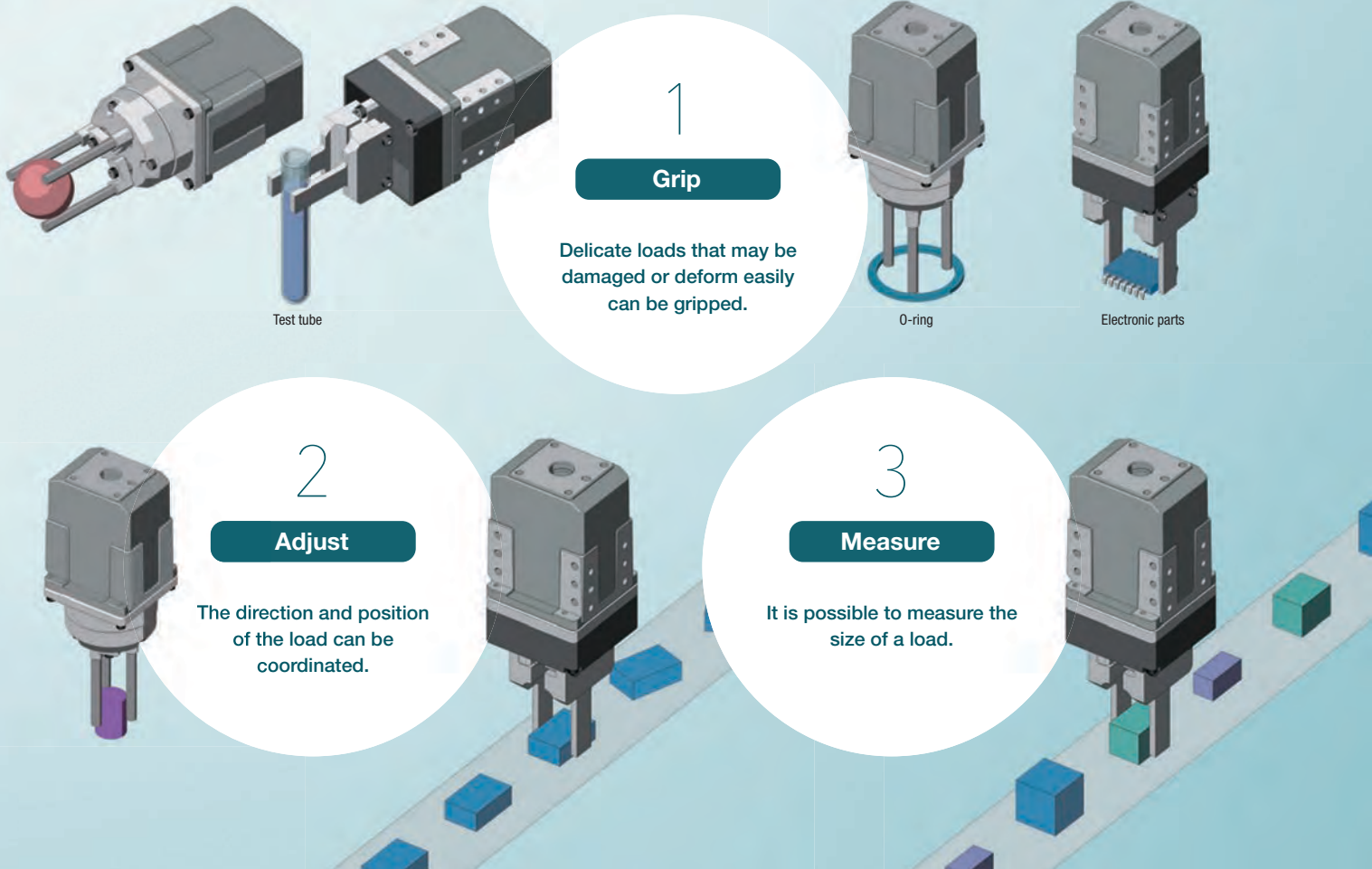

Useful as a Network Compatible End Effector

EtherNet/IP, EtherCAT, and PROFINET compatible drivers are available.
It is optimal as an end effector for equipment or robots controlled over a single network.

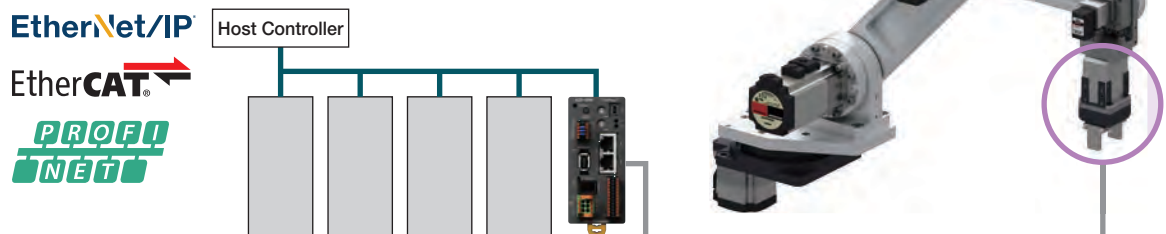

- Installation Flanges for Robots are Available for Installation on Commercially Available Industrial Robots (Collaborative robots).
Flanges on the robot side conform to ISO9409-1 (JIS B 8436).
For product details on product, refer to page 22.



Main Compatible Manufacturers
Yaskawa Electric Corporation
Seiko Epson Corporation

Driven by an α STEP AZ Series Motor

- Built-In battery-free absolute sensor, for constant monitoring of motor position information without an external sensor
- High reliability with closed loop control
- High efficiency technology reduces motor heat generation and saves energy

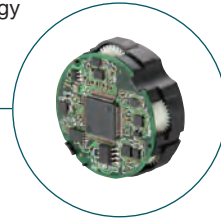
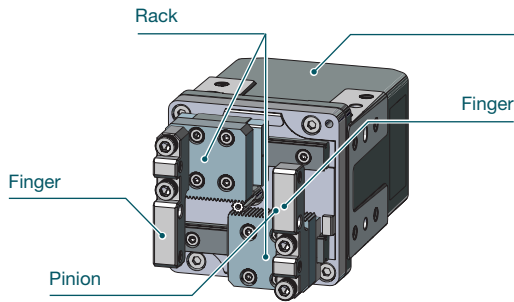

Battery-free Absolute Sensor (ABZO sensor)

The electric gripper driver cable is shared with the AZ Series



For the following contents, refer to the separate AZ Series catalog or the Oriental Motor website.

- Driver Specifications
- Communication Specifications
- Dimensions (Driver, connection cables)
- Connections and Operations • Cables

● Comparison of 2-Finger and 3-Finger Types

Type	2-Finger ^{*1}	3-Finger
Suitable for Gripping Load Shape	Square 	Cylinders, complex shapes, spheres
Moving Range		 When Open: P.C.D. $\phi 30.9$ mm When Closed: P.C.D. $\phi 7$ mm Opening Width: $\phi 23.9$ mm
Max. Gripping Force [N]	25	50
Permissible Load [N] (Permissible axial load [N] ^{*2})	5	15
Mass [kg]	0.38	0.38 (with installation cover) / 0.28 (without installation cover)

*1 The values correspond to the specifications for Model 4

*2 For 3-finger type

Basic Performance of the EH Series of Electric Gripper

Compact and Lightweight

Minimizes the Burden on the Robot

2-Finger/3-Finger

● **EH3-AZAKH**

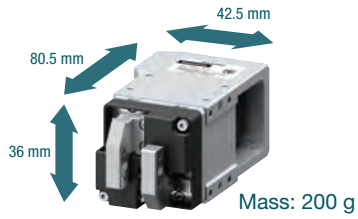

● **EH4-AZAKH**

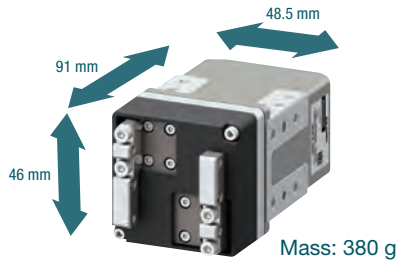

● **EH4T-AZAKH**

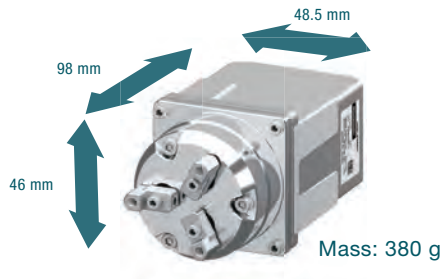

● **EH4T-AZAK**

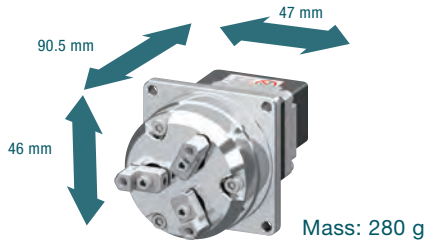

- Reduces the Burden on Each Articulation, Decreasing the Overall Size and Cost of the Robot

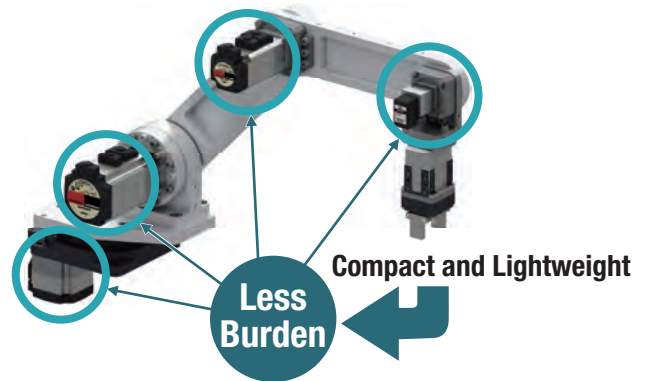

- No Installation Cover Allows for Increased Design Freedom and Weight Reduction

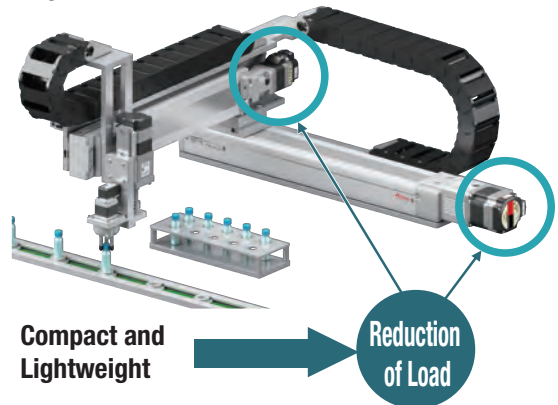

Fine-tuned Grip Force Control

Real Grip, Like that of a Human Hand

2-Finger/3-Finger

- Grip Force and Running Current (Reference values)

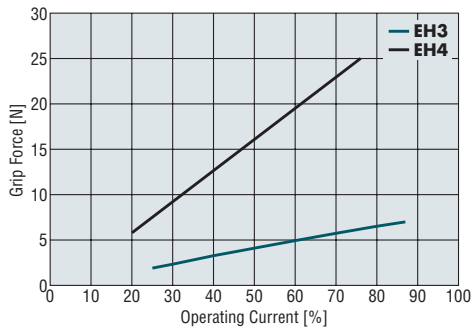

- Grips Gently without Causing Damage



- Two-Stage Gripping without Dropping the Load

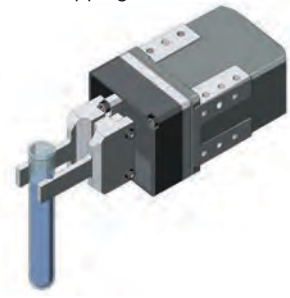

- Transitions in Grip Force <Image>

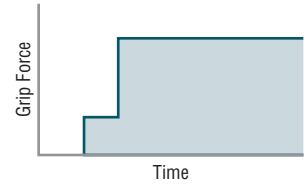
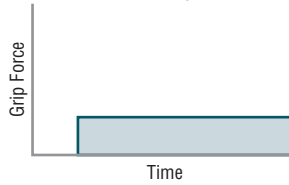

Long Stroke

Compatible with Loads of Different Configurations

2-Finger

- EH3-AZAKH

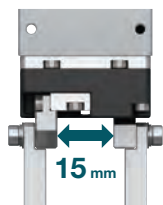

- EH4-AZAKH

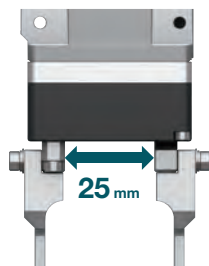

- Continuous Operation without Replacing Attachments, Even for Loads with Uneven Configurations

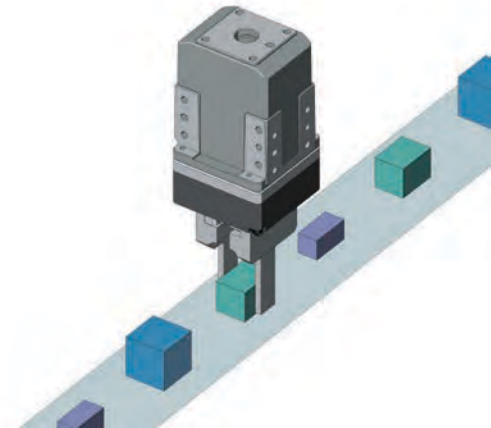

● Please prepare attachments (hooks) separately.

Applications Using the Electric Gripper's "Delicate Grip"

1 Grip

Reliably Grip Loads that may Easily Deform or Break.

2-Finger/3-Finger

Easily set the grip force, grip time, and speed according to the object being gripped.

Safely and reliably grip objects that may easily break, such as glass, and objects that easily deform, such as plastic or springs.

Quick Approach, Slow Grip

The motor approaches the load at high speed. The motor decelerates just before hitting the surface at low speed.

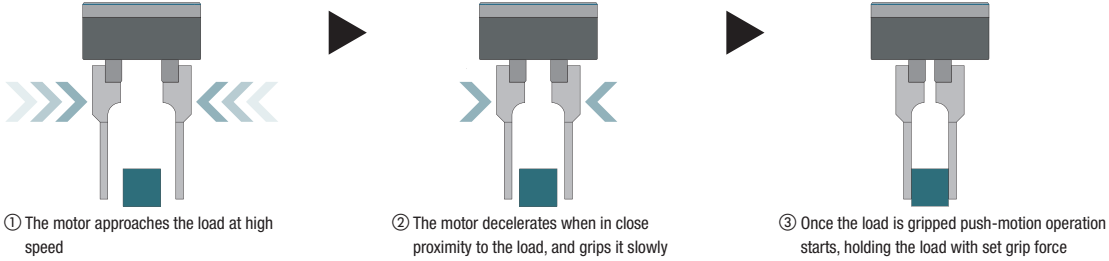

2 Adjust

The Direction and Position of the Load can be Coordinated.

2-Finger/3-Finger

The minimum travel distance of the fingers is 0.02 mm. The direction and position of components can be coordinated by gripping them according to their size.

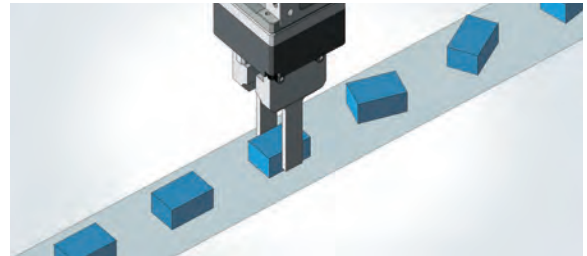
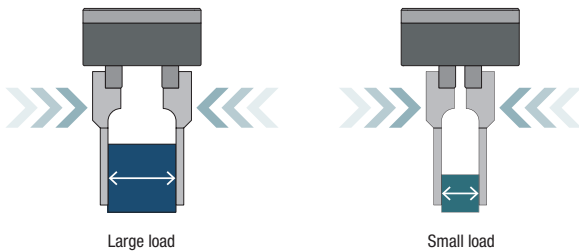

3 Measure

The Size of the Load can be Verified without an External Sensor.

2-Finger

The Size and Presence of a Load are Determined within the Operational Range of the Fingers

The operational range of the pincer is confirmed by the output signal (TLC output, AREA output) from the driver, allowing the size and presence of a load to be determined.

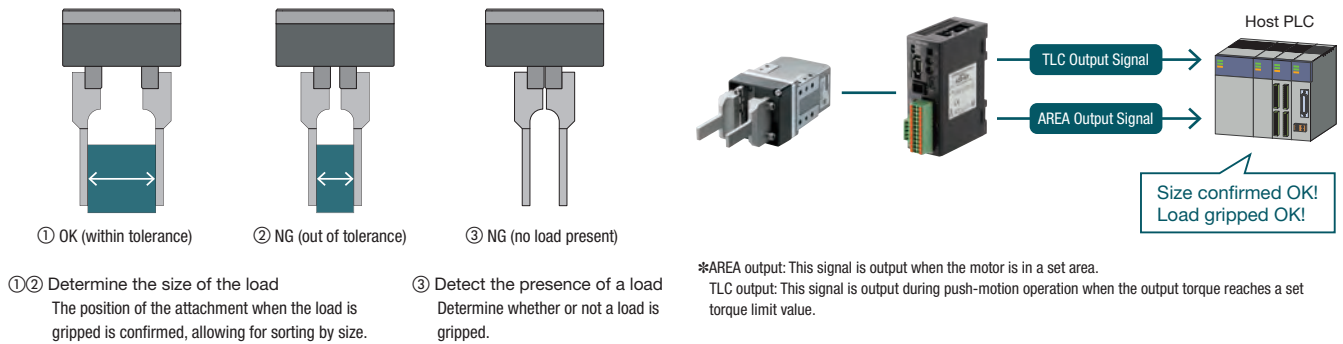

Monitor the Gripper Position to Measure Size

The Coordinates Information Monitoring Function in the driver sends data from the gripper to the host PLC, allowing the size of the load to be measured.

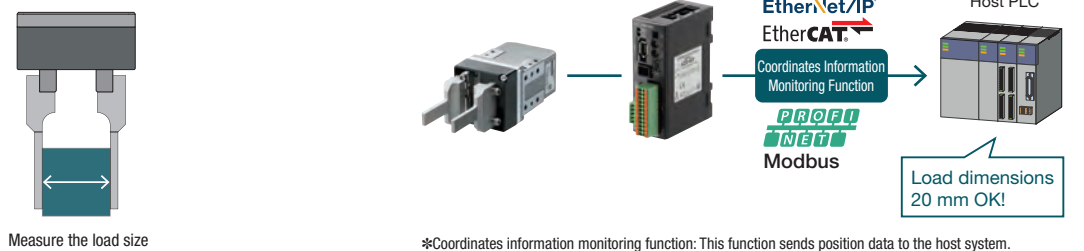

Register the Gripper's Operation Program in the Driver to Distribute the Load on the Host System

● Applicable Products: Built-in controller type drivers and network compatible drivers (excluding EtherCAT)

The **EH** Series can register the state of sensors and other external input signals, as well as its own output signals, in the driver with a simple sequence program while in use.

In simple applications, operation is possible with only a START/STOP command.

Real-time Monitoring of the State of the Motor

Actuators equipped with an **αSTEP AZ** Series, including the **EH** Series, are able to constantly monitor the state of a motor over a network.

Motor Temperature Monitor

Real-time temperature monitoring is possible, even if the robot is inside a case, etc.

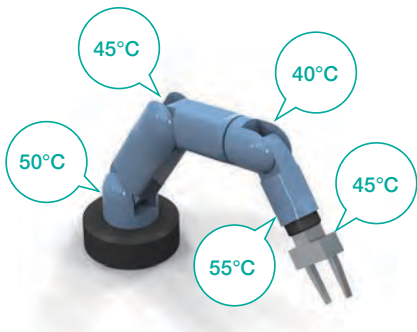

● For monitoring details, refer to the **AZ** Series operating manual.

Cumulative Load Monitor

Besides an instantaneous load factor monitor, the load factor in the motor's operating pattern can also be obtained via area and detected as a value. This allows long-term changes in load due to age deterioration and other factors to be understood.

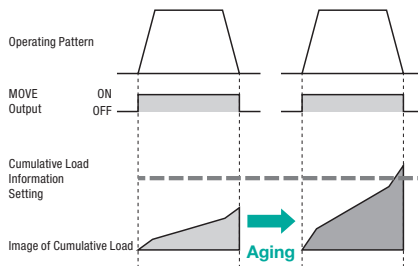

ODO/TRIP Monitor

The cumulative number of rotations can be monitored, like with a car's gauges. An information signal can be output when a set threshold is reached. This is useful for maintenance and other applications.

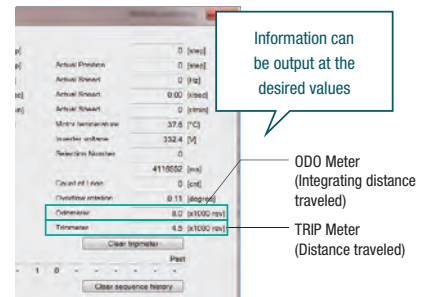

◆ Dedicated Support Software MEXE02 (Free download)

Operating data editing, parameter setting, and other such basic settings can be easily made on a computer. Simple sequence programs can also be created.



Users love that it is easy to operate even without a background in electrical design!

Display and input the traveling amount, speed, etc. in the desired units (mm, deg)

Simplified program with simple sequence function

Copy and back up settings



Easy-to-understand and easy-to-use
Intuitive operability





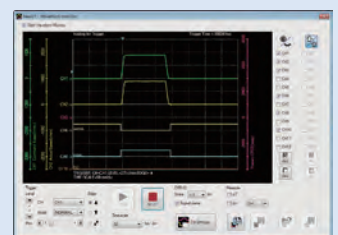

Teaching is also possible from a computer







Check the signal's input status
Also equipped with waveform monitor

Product Line of EH Series

Electric Grippers

<p>EH3-AZAKH</p> 	<p>EH4-AZAKH</p> 	<p>EH4T-AZAKH</p> 	<p>EH4T-AZAK</p> 
-----------------------------------------------------------------------------------------------------------	-----------------------------------------------------------------------------------------------------------	------------------------------------------------------------------------------------------------------------	-------------------------------------------------------------------------------------------------------------

Drivers DC Input

<p>Built-in Controller Type FLEX</p> <p>Set the positioning data in the driver (256 points). FA network control is possible with a network converter (sold separately).</p> 	<p>Pulse Input Type with RS-485 Communication</p> <p>The motor's position, speed, torque, alarms, and temperature can be monitored via RS-485 communication.</p> 	<p>Pulse Input Type</p> <p>The motor is controlled from a positioning module (pulse generator).</p> 	<p>Network Compatible</p> <p>The driver can be directly controlled from a host control device over an FA network.</p>  <p>EtherNet/IP EtherCAT PROFINET Modbus (RTU)</p>	<p>Mini Driver</p> <p>More compact and lightweight than box-type driver. Network compatible driver.</p> <p>EtherNet/IP EtherCAT Modbus (RTU)</p> 
---------------------------------------------------------------------------------------------------------------------------------------------------------------------------------------------------------------------------------------------------------------------------------	-----------------------------------------------------------------------------------------------------------------------------------------------------------------------------------------------------------------------------------------------------------	----------------------------------------------------------------------------------------------------------------------------------------------------------------------------------------------	--------------------------------------------------------------------------------------------------------------------------------------------------------------------------------------------------------------------------------------------------------------------------------	-----------------------------------------------------------------------------------------------------------------------------------------------------------------------------------------------------------------------------------------------------

◆ For Delicate Operations, We Recommend the EH Series Over a Pneumatic Gripper!

<p>Adjust the Grip Force in 1% Increments</p>	<p>Adjustment with a pneumatic gripper's regulator (pressure reducing valve) is unnecessary. The grip force can be easily and finely adjusted with digital settings.</p>	<p>Adjust the Speed in 0.02 mm/s Increments</p>	<p>Adjustment with a pneumatic gripper's speed controller (speed control valve) is unnecessary. Speed regulation is easy as a result of control with a stepper motor, making gripping possible at low speeds.</p>
<p>Adjust the Traveling Amount in 0.02 mm Increments</p>	<p>This gripper utilizes the height of the stepper motor's positioning accuracy. This allows loads of various configurations to be approached.</p>	<p>Position Monitoring with an Absolute Sensor</p>	<p>Feedback of detailed position information allows for not only grip and transportation, but also the size of the load to be determined.</p>

System Configuration

Combination of Electric Gripper and Built-in Controller Type Driver, or Pulse Input Type Driver with RS-485 Communication

An example of a configuration using I/O control or RS-485 communication is shown below. Electric gripper, driver, and a connection cable/flexible connection cable are ordered separately.

For a pulse input type driver system configuration, please see the Oriental Motor website.

- Required for operation
- Optional accessory

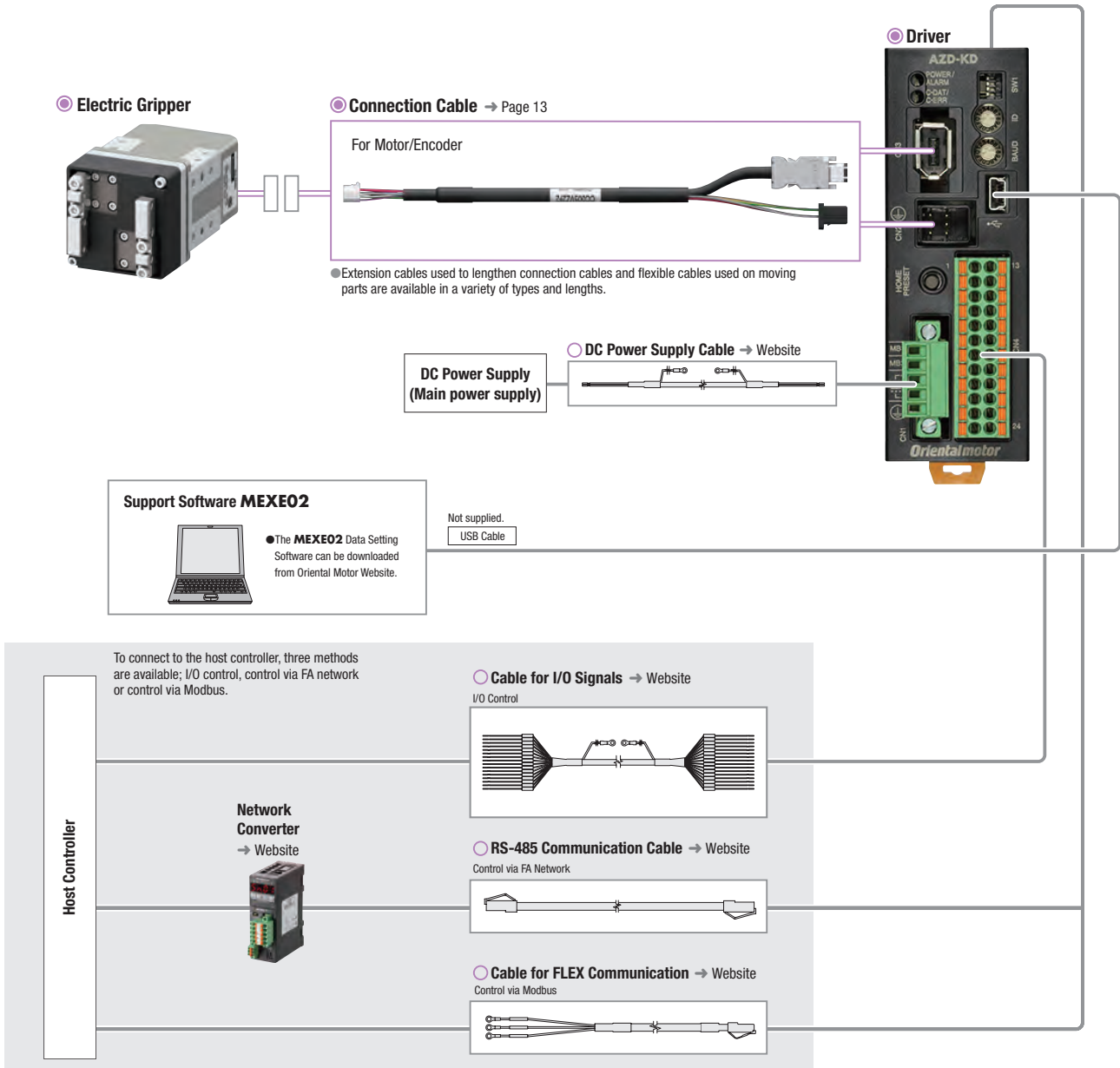

Example of System Configuration

Electric Gripper	Driver	Cables	
		Connection Cable (1 m)	Cable for I/O Signals Connector Type (1 m)
EH4-AZAKH	AZD-KD	CC010VZ2F2	CC16D010B-1
<input checked="" type="radio"/>	<input checked="" type="radio"/>	<input checked="" type="radio"/>	<input type="radio"/>

The system configuration shown above is an example. Other combinations are also available.

Note

The motor cable and encoder cable from the motor cannot be connected directly to the driver. When connecting to a driver, use a connection cable.

● **Combination of Electric Gripper and Network Compatible Driver**

An example of a configuration using I/O control with an EtherNet/IP-compatible driver or EtherNet/IP is shown below. Electric gripper, driver, and a connection cable/flexible connection cable are ordered separately.

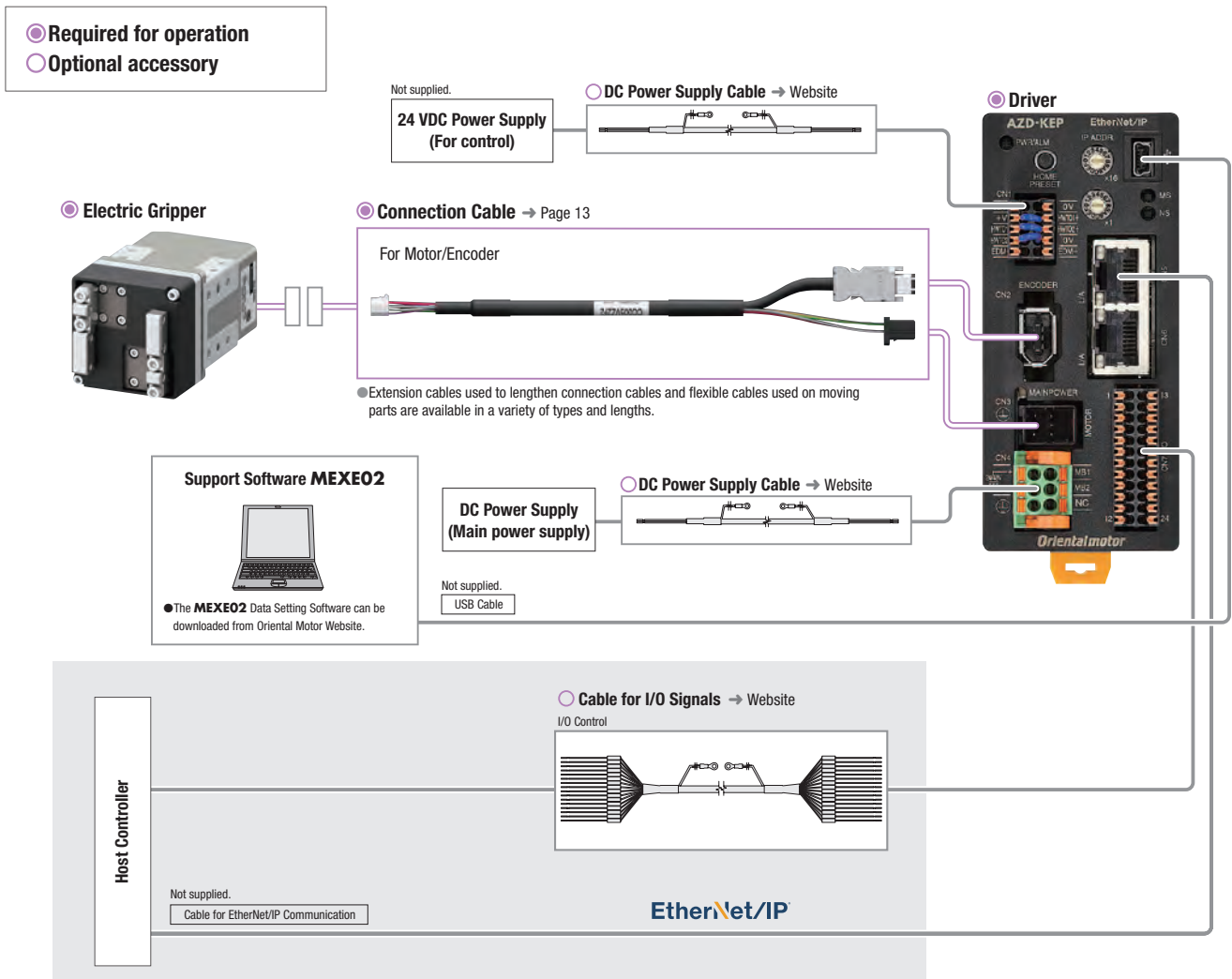

● **Example of System Configuration**

Electric Gripper	Driver	Cables	
		Connection Cable (1 m)	Cable for I/O Signals General-Purpose Type (1 m)
EH4-AZAKH	AZD-KEP	CC010VZ2F2	CC16D010B-1
○	○	○	○

● The system configuration shown above is an example. Other combinations are also available.

Note

● The motor cable and encoder cable from the motor cannot be connected directly to the driver. When connecting to a driver, use a connection cable.

Product Number

Electric Gripper

EH 4 T - AZ A K H

① ② ③ ④ ⑤ ⑥ ⑦

①	Series Name	EH: EH Series
②	Product Number	3: 36 mm (W)×36 mm (H) (Finger side) 4: 46 mm (W)×46 mm (H) (Finger side)
③	Finger Type	None: 2-Finger Type T: 3-Finger Type
④	Motor	AZ: AZ Series
⑤	Additional Function	A: Without Additional Function
⑥	Motor Type	K: DC Power Supply Input
⑦	Configuration	H: With installation cover None: No installation cover

Driver

AZD - K D

① ② ③

①	Driver Type	AZD: AZ Series Driver
②	Power Supply Input	K: 24 VDC
③	Product Line	D: Built-in Controller Type X: Pulse Input Type with RS-485 Communication Blank: Pulse Input Type EP: EtherNet/IP Compatible ED: EtherCAT Drive Profile Compatible PN: PROFINET Compatible

Connection Cable/Flexible Connection Cable

CC 050 V Z 2 F 2

① ② ③ ④ ⑤ ⑥ ⑦

①		CC: Cable
②	Length	005: 0.5 m 010: 1 m 015: 1.5 m 020: 2 m 025: 2.5 m 030: 3 m 040: 4 m 050: 5 m 070: 7 m 100: 10 m 150: 15 m 200: 20 m
③	Reference Number	
④	Applicable Model	Z: AZ Series
⑤	Reference Number	2: Frame Size 20 mm, 28 mm
⑥	Cable Type	F: Connection Cable R: Flexible Connection Cable
⑦	Cable Specifications	2: DC Power Supply Input

Product Line

Electric Gripper

- ◇ 2-Finger Type
With Installation Cover

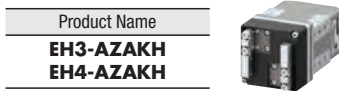

- ◇ 3-Finger Type
With Installation Cover



- ◇ 3-Finger Type
Without Installation Cover



Driver

- ◇ Built-in Controller Type



- ◇ Pulse Input Type
with RS-485 Communication

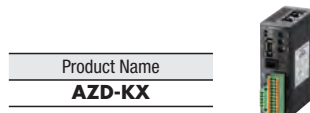

- ◇ Pulse Input Type

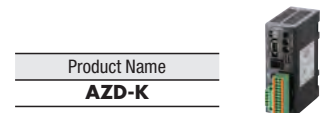

- ◇ EtherNet/IP Compatible



- ◇ EtherCAT
Drive Profile Compatible



- ◇ PROFINET Compatible

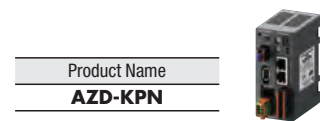

Connection Cable/Flexible Connection Cable

Use a flexible connection cable if the cable will be bent.

- ◇ For Motor/Encoder



Product Line	Length [m]	Product Name
Connection Cable	0.5	CC005VZ2F2
	1	CC010VZ2F2
	1.5	CC015VZ2F2
	2	CC020VZ2F2
	2.5	CC025VZ2F2
	3	CC030VZ2F2
	4	CC040VZ2F2
	5	CC050VZ2F2
	7	CC070VZ2F2
	10	CC100VZ2F2
	15	CC150VZ2F2
20	CC200VZ2F2	

Product Line	Length [m]	Product Name
Flexible Connection Cable	0.5	CC005VZ2R2
	1	CC010VZ2R2
	1.5	CC015VZ2R2
	2	CC020VZ2R2
	2.5	CC025VZ2R2
	3	CC030VZ2R2
	4	CC040VZ2R2
	5	CC050VZ2R2
	7	CC070VZ2R2
	10	CC100VZ2R2
	15	CC150VZ2R2
20	CC200VZ2R2	

Included Items

Electric Gripper

Operating Manual: 1 Copy

Driver

Type	Included Items	Connector
Built-in Controller Type Pulse Input Type with RS-485 Communication Pulse Input Type		CN1 Connector (1 pc.) CN4 Connector (1 pc.)
EtherNet/IP Compatible EtherCAT Drive Profile Compatible PROFINET Compatible		CN1 Connector (1 pc.) CN4 Connector (1 pc.) CN7 Connector (1 pc.)

Connection Cable/Flexible Connection Cable

Type	Included Items	Operating Manual
Connection Cable		—
Flexible Connection Cable		1 Set

The cables and drivers that can be used with the actuators are common with the **αSTEP AZ Series**.

The **αSTEP AZ** has a separate catalogue.
When selecting a product, please also use the separate catalog or the mini driver separate catalog.



Explanation of Terminology in Specifications Table

Type	2-Finger	3-Finger
Maximum Gripping Force	This is the maximum force used to grip the load.	
Repetitive Positioning Accuracy	A value indicating the degree of error that generates when positioning is performed repeatedly to the same position in the same direction (measured at a constant temperature and under a constant load).	-
Backlash	This is the play of the finger when the motor shaft is fixed.	-
Stroke	This is the maximum distance that the finger can open or close.	
Gripping Diameter	-	This is the diameter of the load that can be gripped.
Gear Ratio	-	This is the ratio of the rotation speed between the input speed from the motor and rotational speed of the finger.
Maximum Speed	This is the maximum speed that the fingers can open or close.	
Maximum Acceleration	This is the maximum acceleration at which the fingers can open or close.	-
Push-Motion Speed	This is the operating speed for push-motion operation (gripping operation)	
Minimum Traveling Amount	This is the factory setting for the traveling amount per 1 pulse.	-
Permissible Load	This is the permissible external force.	
Static Permissible Moment	This is the permissible moment during gripping operation.	-
Permissible Axial Load	-	This is the permissible load that can be applied in the finger's axial direction.
Permissible Radial Load	-	This is the permissible load that can be applied perpendicular to the finger.

● Load Moment Formula

$$\frac{|\Delta M_P|}{M_P} + \frac{|\Delta M_Y|}{M_Y} + \frac{|\Delta M_R|}{M_R} \leq 1$$

ΔM_P : Load moment in the pitching direction [Nm]

ΔM_Y : Load moment in the yawing direction [Nm]

ΔM_R : Load moment in the rolling direction [Nm]

M_P : Permissible moment in the pitching direction [Nm]

M_Y : Permissible moment in the yawing direction [Nm]

M_R : Permissible moment in the rolling direction [Nm]

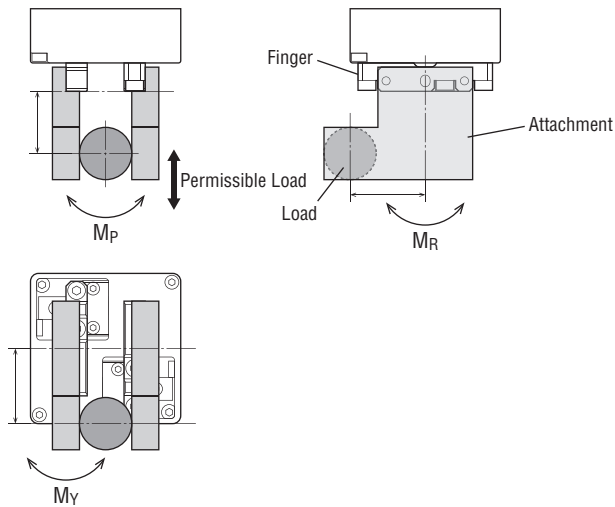

● Correlation between radial load and gripping position (reference value)

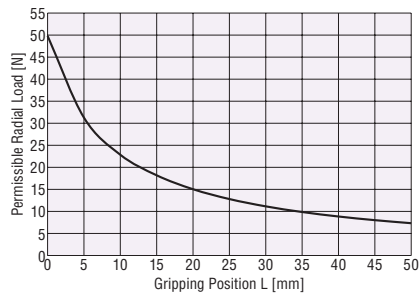
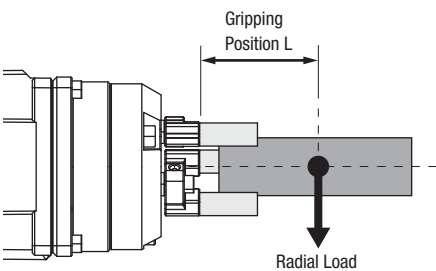

Specifications

2-Finger Type

Actuator Product Name		EH3-AZAKH	EH4-AZAKH
Motor (AZ Series)		AZM14	AZM24
Maximum Grip Force [N]		7	25
Repetitive Positioning Accuracy [mm]	each side	±0.02	±0.02
Backlash [mm]	each side	0.2	0.1
Stroke [mm]	both sides	15	25
	each side	7.5	12.5
Max. Speed [mm/s]	both sides	156	156
	each side	78	78
Maximum Acceleration [m/s ²]	both sides	20	20
	each side	10	10
Push Speed [mm/s]	both sides	20	20
	each side	10	10
Minimum Travel Amount [mm]	both sides	0.02	0.02
	each side	0.01	0.01
Permissible Load [N]		2	5
Static Permissible Moment [Nm]*		Mp: 0.7 Mv: 0.2 Mr: 0.2	Mp: 1.2 Mv: 0.12 Mr: 0.4

*The static permissible moment at the finger end. The load, attachment mass, grip force (including impact load), etc. should be considered when using.

Note

- The actual load mass that can be transported varies greatly depending on the attachment, the friction coefficient of the load, and the acceleration. Use it with a sufficient margin, with an upper limit of 1/10 of the grip force.

3-Finger Type

Actuator Product Name	With Installation Cover	EH4T-AZAKH
	Without Installation Cover	EH4T-AZAK
Equipped Motor (AZ Series)		AZM24
Gear Ratio		5
Maximum Gripping Force [N]		50
Gripping Diameter [mm]*1*2	Grips the outside diameter of the object to be gripped	φ2 - φ24
	Grips the inner diameter of the object to be gripped	φ14 - φ36
Max. Speed [r/min]*3		1200
Push-Motion Speed [r/min]*3		12
Permissible Axial Load [N]		15
Permissible Radial Load [N]*4		15

*1 This value takes into account a clearance of approximately 0.5 mm (min. value) relative to the diameter (D) of the object to be gripped.

*2 When the attachment diameter (d) is φ6 mm.

*3 This is the finger speed.

*4 This is the value 10 mm from the attachment installation surface. This is the sum of the mass of the load and the attachment and the gripping force (includes shock load).

Note

- The actual mass of the load that can be transported varies greatly depending on the attachment, friction coefficient of the load, acceleration, and other factors. Use 1/10 of the gripping force as the upper limit and allow sufficient margin.
- Depending on the design of the object to be gripped and the attachment, the gripping force may exceed the maximum gripping force. If the product is used under these conditions, it may be damaged. If the maximum gripping force is exceeded, adjust the running current to reduce the actual gripping force to less than the maximum gripping force.

Relationship between Push Force (Grip Force) and Current

The gripping movement of the electric gripper depends on the push-motion operation. The push force (grip force) is set by the operating current of the motor.

Actual Push Force (Grip force)

The push force (grip force) and current values are shown below as a reference. Check it on the actual assembled equipment.

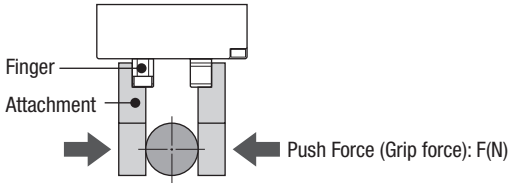

EH3-AZAKH

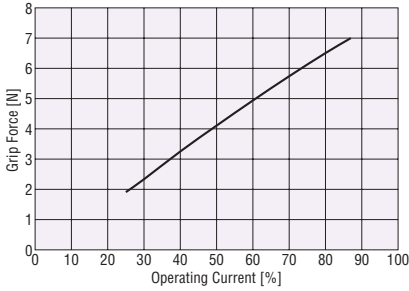

- Set the grip force during push-motion operation to 7 N or less.
- Set the operation speed during push-motion operation to 10 mm/s or less (single side).

EH4-AZAKH

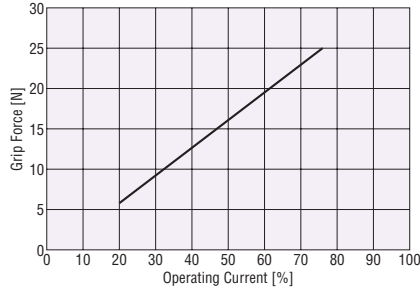

- Set the grip force during push-motion operation to 25 N or less.
- Set the operation speed during push-motion operation to 10 mm/s or less (single side).

Relationship between Push Force (Gripping Force) and Current

The gripping movement of the electric gripper is performed with push-motion operation. The push force (gripping force) is set by the operating current.

3-Finger Type Push Force (Gripping force) Reference Values

Reference values for the outer diameter (or inner diameter) of the gripped object, attachment diameter and gripping force at each operating current are shown below. Check the actual push force (gripping force) using the equipment.

The gripping force of the 3-finger type varies depending on the size of the load to be gripped.

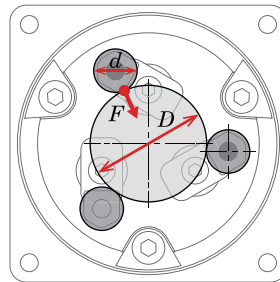
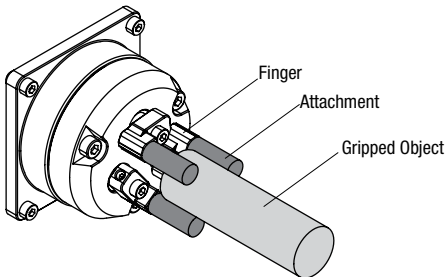

Front View

- F : Gripping force [N]
- d : Attachment diameter [mm]
- D : Outer diameter (or inner diameter) of gripped object [mm]

Relationship between Gripped Object, Attachment Diameter and Push Force (Gripping force) [Reference Value]

Gripping force can be set by operating current (%).

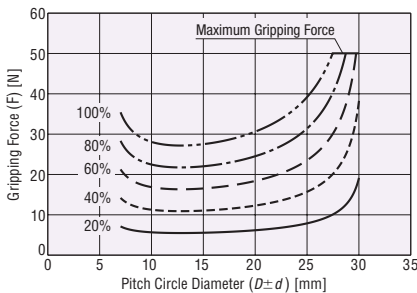

- When gripping the outer diameter of the gripped object.
 $D+d$: Pitch circle diameter [mm]
- When gripping the inner diameter of the gripped object.
 $D-d$: Pitch circle diameter [mm]

◇Gripping Force and Gripping Diameter Formulas

The gripping force can be calculated using the formula shown below.

- Because the gripping force varies with the diameter of the object to be gripped, adjust the gripping force according to the size, mass, and strength of the object.

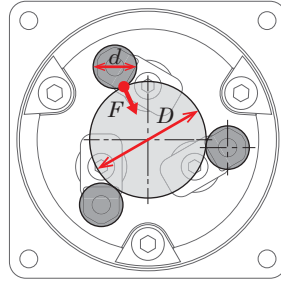
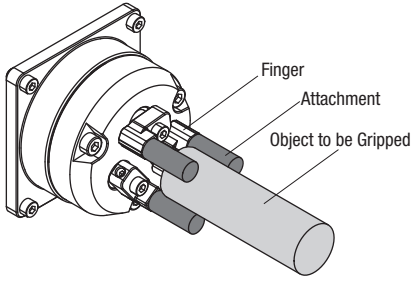

Front view

F : Gripping force [N]
 d : Attachment diameter [mm]
 D : Outer diameter (or inner diameter) of the object to be gripped [mm]

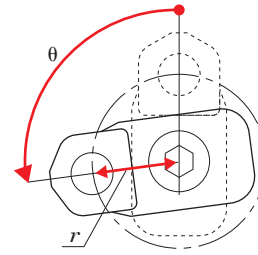

Finger operation

R : Attachment's rotation radius [mm] (=6.4)
 θ : Finger's rotation angle[°]

●Gripping force formula

$$F = \frac{0.174}{r \times 10^{-3}} \div \sin \left\{ \theta - \tan^{-1} \left(\frac{r \times \sin \theta}{9.05 + r \times \cos \theta} \right) \right\}$$

●Gripping diameter formula

- When gripping the outer diameter of the object to be gripped

$$D = 2 \times \sqrt{(9.05 + r \times \cos \theta)^2 + (r \times \sin \theta)^2} - d$$

- When gripping the inner diameter of the object to be gripped

$$D = 2 \times \sqrt{(9.05 + r \times \cos \theta)^2 + (r \times \sin \theta)^2} + d$$

■ Driver Specifications

Product Name		AZD-KD, AZD-KX, AZD-K	AZD-KEP, AZD-KED, AZD-KPN
Main Power Supply	Input Voltage	24 VDC ±5%	
	Input Current	0.5 A	0.4 A
Control Power Supply	Input Voltage	24 VDC ±5%	
	Input Current	—	0.15 A

■ General Specifications

		Electric Gripper	Driver
Thermal Class		130 (B)	—
Insulation Resistance		100 MΩ or more when a 500 VDC megger is applied between the following places: · Between the case and motor windings	100 MΩ or more when a 500 VDC megger is applied between the following places: · Between the protective earth terminal and the power supply terminal
Dielectric Strength		Sufficient to withstand the following for 1 minute: · Between the case and motor windings: 0.5 kVAC, 50 Hz or 60 Hz	—
Operating Environment (In operation)	Ambient Temperature	0 to +40°C (Non-freezing)*	0 to +50°C (Non-freezing)
	Ambient Humidity	85% or less (Non-condensing)	
	Atmosphere	Use in an area without corrosive gases and dust. The product should not be exposed to water, oil or other liquids.	
Degree of Protection		—	IP10

* Based on Oriental Motor's internal measurement conditions

Note

- Disconnect the motor and driver when taking an insulation resistance measurement or performing a dielectric voltage withstand test. Also, do not perform these tests on the absolute sensor part of the motor.

Travel Direction

The default factory setting for direction of travel is as follows:

2-Finger Type

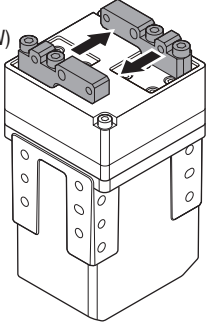
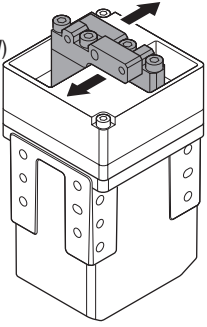
Travel Direction	Travel Direction
<p>Fingers closing + Direction (CW)</p> 	<p>Fingers opening - Direction (CCW)</p> 

3-Finger Type

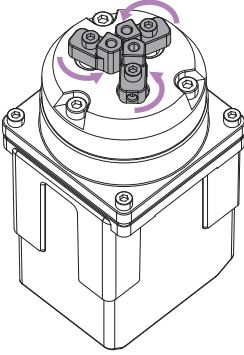
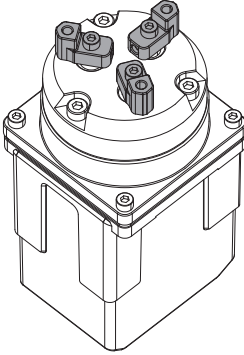
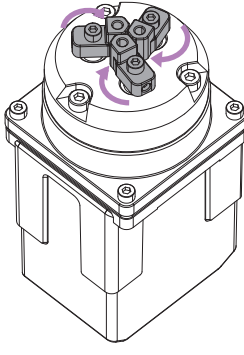
Traveling Direction	Traveling Direction	Traveling Direction
<p>Travels to inner side (Closes) - Side (CCW)</p> 	<p>Home (Open)</p> 	<p>Travels to inner side (Closes) + Side (CW)</p> 

Dimensions (Unit: mm)

● 2-Finger Type With Installation Cover

Product Name	Mass [kg]
EH3-AZAKH	0.2

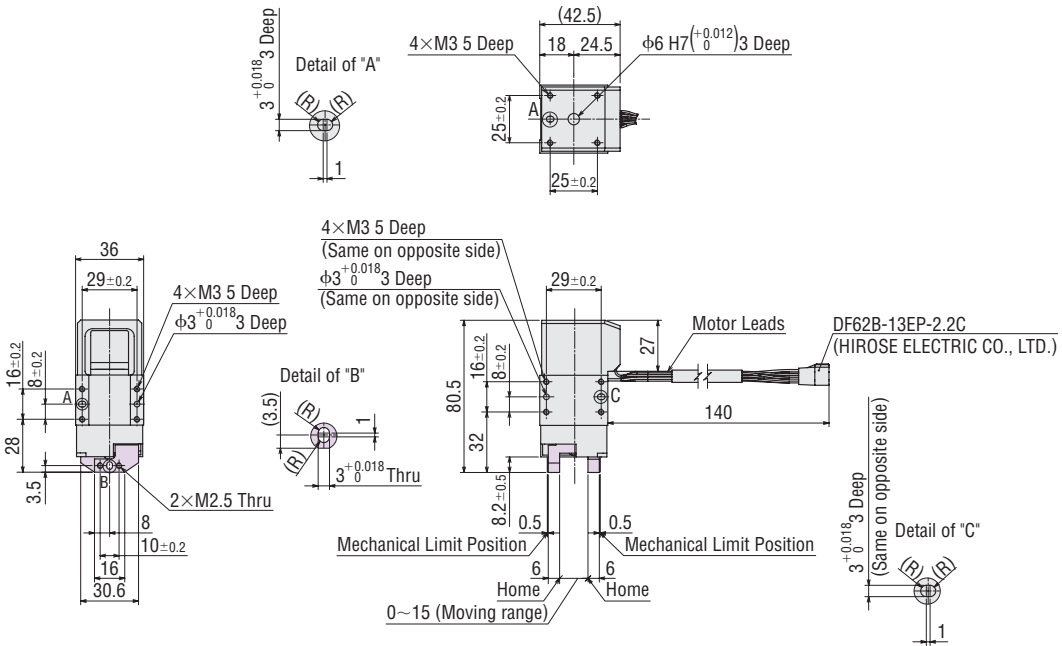

● The shaded areas are moving parts.

Product Name	Mass [kg]
EH4-AZAKH	0.38

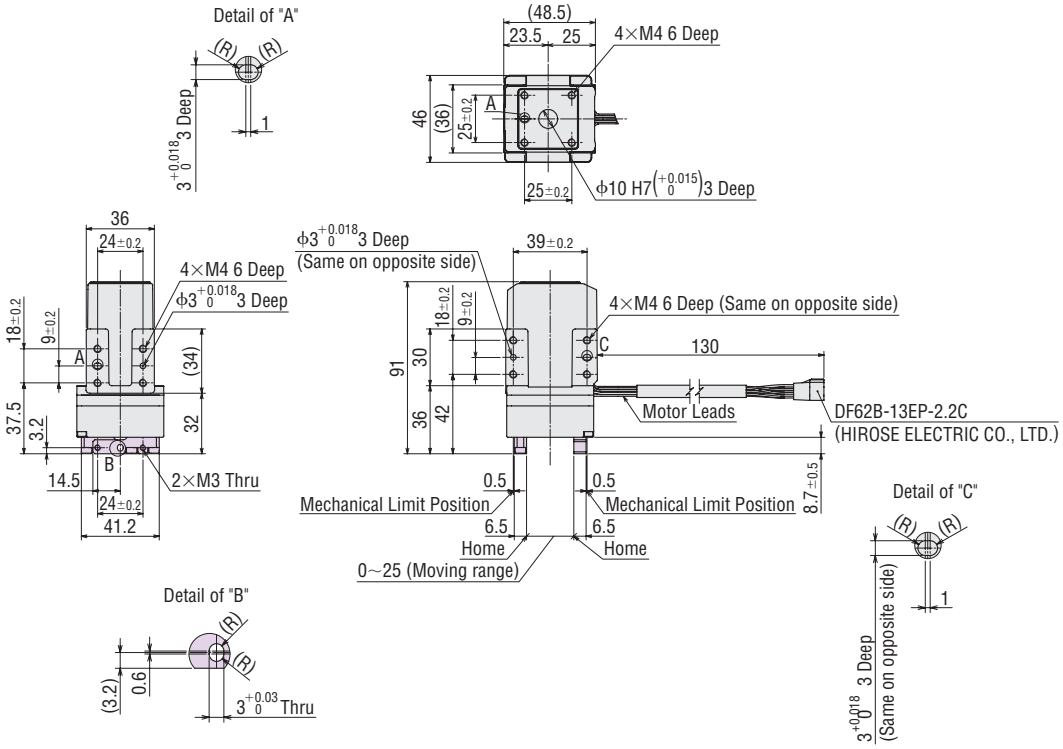

● The shaded areas are moving parts.

● 3-Finger Type

◇ With Mounting Cover

Product Name	Mass [kg]
EH4T-AZAKH	0.38

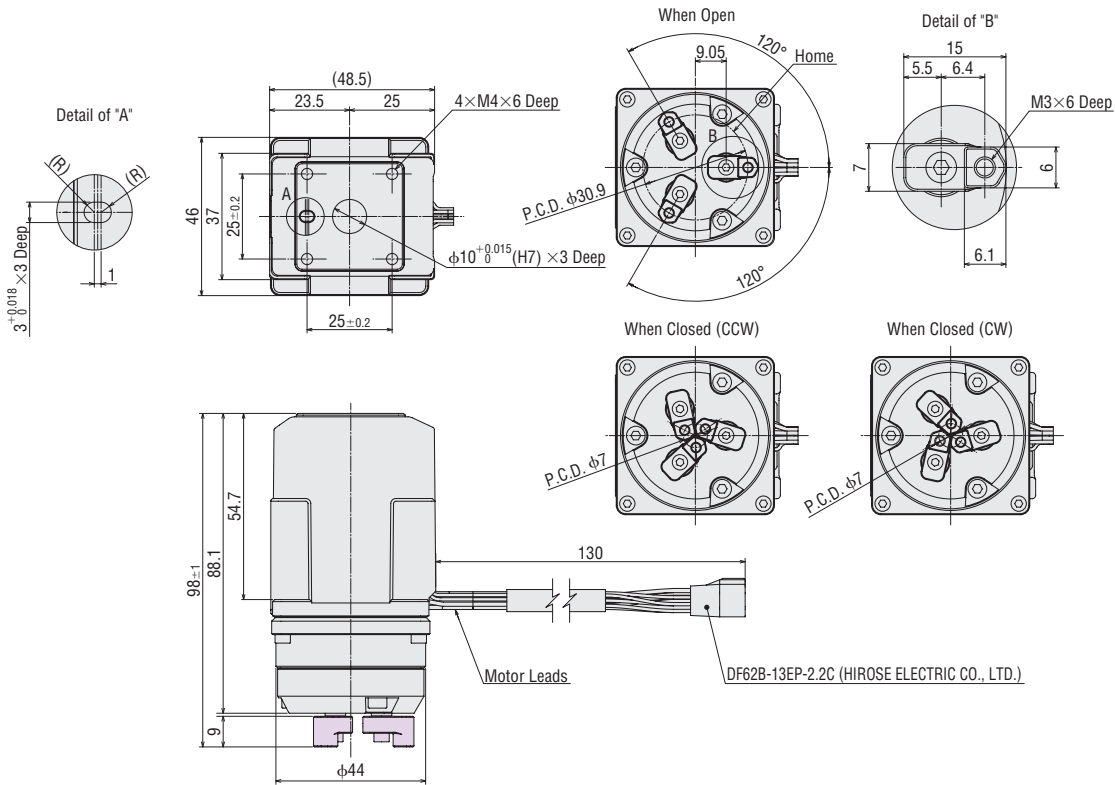

◇ Without Mounting Cover

Product Name	Mass [kg]
EH4T-AZAK	0.28

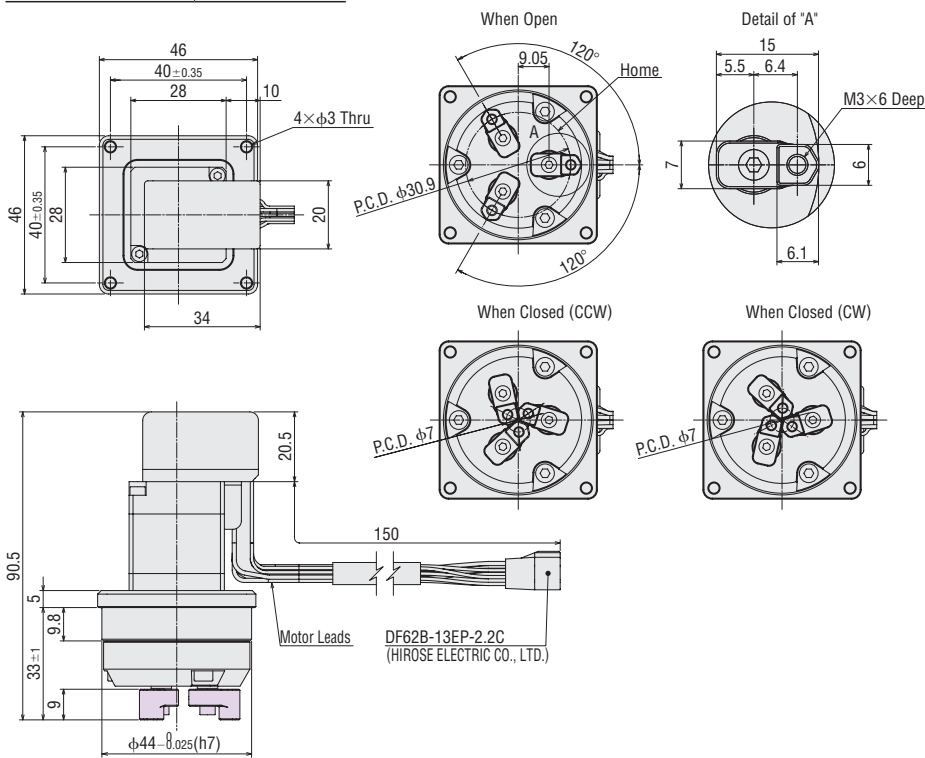

● The shaded areas are moving parts.

Peripheral Equipment

Installation Flange for Robots

This flange can be installed on commercially available industrial robots.

It helps reduce man-hours for jig design and production.

Installation flanges on the robot side conform to ISO9409-1 (JIS B 8436).

They can be installed on each robot manufacturer's SCARA robots and vertical articulated robots.

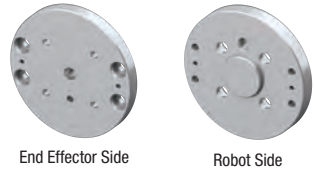

Product Line

Product Name	Applicable ISO Standards on Robot Side	Applicable Product
P3F1	Conforms to ISO 9409-1-31.5-4-M5	EH3
P3F2		EH4
P5F1	Conforms to ISO 9409-1-50-4-M6	EH3
P5F2		EH4

Included Items

Positioning Pins, Hexagonal Socket Head Screws*, Operating Manual

*Bolts for connecting the industrial robot and the installation flange for robot are not supplied.

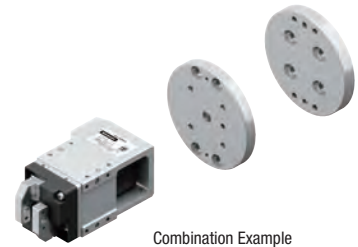

Dimensions (Unit: mm)

Product Name	Mass [kg]
P3F1	0.13
P3F2	
P5F1	
P5F2	

P3F1

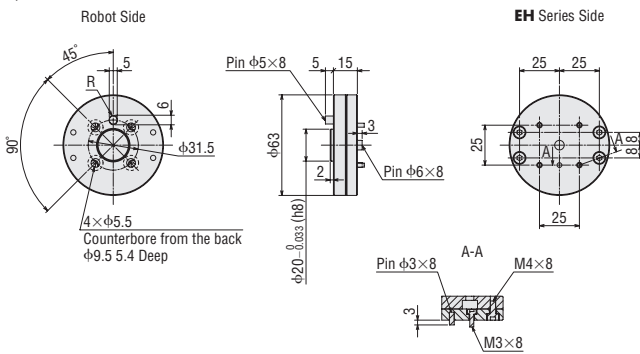

P3F2

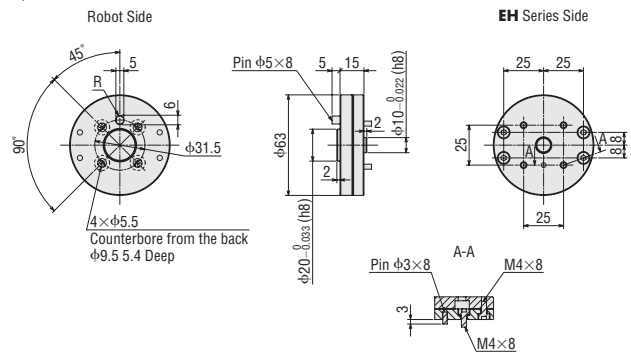

P5F1

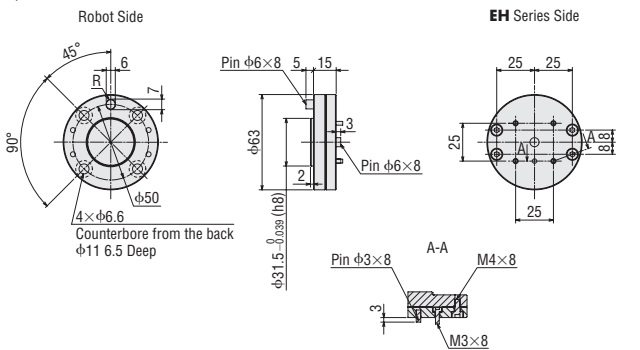

P5F2

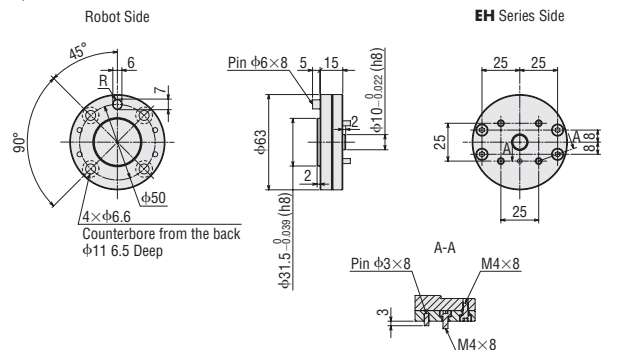

Examples of Industrial Robots that Can be Combined

Yaskawa Electric Corporation

Example of Compatible Product:
-MOTOMAN-HC Series



Seiko Epson Corporation

Example of Compatible Product:
-T Series
-VT



Product Variation with the **AZ** Series

Controllability is consolidated across all product groups that contain the **AZ** Series.



Orientalmotor

These products are manufactured at plants certified with the international standards **ISO 9001** (for quality assurance) and **ISO 14001** for systems of environmental management).

Specifications are subject to change without notice. This catalogue was published in January 2024.

ORIENTAL MOTOR (EUROPA) GmbH

European Headquarters

Schießstraße 44
40549 Düsseldorf, Germany
Tel: 0211 5206700 Fax: 0211 52067099

Spanish Office

C/Caléndula 93 - Ed. E - Miniparc III
28109 El Soto de La Moraleja,
Alcobendas (Madrid), Spain
Tel: +34 918 266 565

ORIENTAL MOTOR (UK) LTD.

UK Headquarters

Unit 5, Faraday Office Park,
Rankine Road, Basingstoke,
Hampshire RG24 8AH, U.K.
Tel: +44 1256 347090 Fax: +44 1256 347099

ORIENTAL MOTOR SWITZERLAND AG

Switzerland Headquarters

Badenerstrasse 13
5200 Brugg AG, Switzerland
Tel: +41 56 560 50 45 Fax: +41 56 560 50 47

ORIENTAL MOTOR ITALIA s.r.l.

Italy Headquarters

Via XXV Aprile 5
20016 Pero (MI), Italy
Tel: +39 2 93906346 Fax: +39 2 93906348

ORIENTAL MOTOR (FRANCE) SARL

France Headquarters

56, Rue des Hautes Pâtures
92000 Nanterre, France
Tel: +33 1 47 86 97 50 Fax: +33 1 47 82 45 16

Customer Service Center

(Support in German & English)

00800 22 55 66 22 *

Mon - Thu: 08:00 - 16:30 CET

Friday: 08:00 - 15:00 CET

*Free Call Europe

info@orientalmotor.de

WWW.ORIENTALMOTOR.EU

EN | DE | UK | IT | FR | ES